



Selection: Semi-hermetic Screw Compressors HS

Input Values

Compressor model	HSK7451-70	Frequency compressor	--
Refrigerant	R404A	Power supply	400V-3-50Hz
Reference temperature	Dew point temp.	Useful superheat	100%
Liq. subc. (in condenser)	0 K	Additional cooling	Automatic
Suct. gas superheat	10,00 K	Max. discharge gas temp.	80,0 °C
Operating mode	Standard		

Result

Q [W]	Cooling capacity	mHP [kg/h]	Mass flow HP
P [kW]	Power input	Qac [kW]	Additional cooling
I [A]	Current	tcu [°C]	Liquid temp.
COP [-]	COP/EER	pm [bar(a)]	ECO pressure
mLP [kg/h]	Mass flow LP	Qsc [kW]	sub cooler capacity (ECO)

tc	to	5°C	0°C	-5°C	-10°C	-15°C	-20°C	-25°C	-30°C
30°C	Q [W]	243424	202746	167632	137453	111642	89693	--	--
	P [kW]	39,0	39,5	40,0	40,5	40,8	40,9		
	I [A]	64,4	65,2	65,9	66,6	67,0	67,2		
	COP [-]	6,24	5,13	4,19	3,40	2,74	2,19		
	mLP [kg/h]	6509	5534	4676	3922	3262	2686		
	mHP [kg/h]	6509	5534	4676	3922	3262	2686		
	Qac [kW]	--	--	--	--	--	--		
	tcu [°C]	29,6	29,6	29,6	29,6	29,6	29,6		
	pm [bar(a)]	--	--	--	--	--	--		
	Qsc [kW]	--	--	--	--	--	--		
40°C	Q [W]	208317	172729	142104	115874	93528	74611	--	--
	P [kW]	50,0	50,5	50,9	51,2	51,4	51,4		
	I [A]	80,5	81,3	82,0	82,4	82,6	82,6		
	COP [-]	4,17	3,42	2,79	2,26	1,82	1,45		
	mLP [kg/h]	6329	5372	4530	3791	3144	2581		
	mHP [kg/h]	6329	5372	4530	3791	3144	2581		
	Qac [kW]	--	--	--	--	--	3,57		
	tcu [°C]	39,6	39,6	39,6	39,6	39,6	39,6		
	pm [bar(a)]	--	--	--	--	--	--		
	Qsc [kW]	--	--	--	--	--	--		
50°C	Q [W]	169912	139794	113964	91924	73227	57474	--	--
	P [kW]	64,2	64,8	65,1	65,2	65,1	64,9		
	I [A]	101,9	102,9	103,4	103,5	103,4	103,0		
	COP [-]	2,65	2,16	1,75	1,41	1,12	0,89		
	mLP [kg/h]	6051	5118	4295	3573	2940	2387		
	mHP [kg/h]	6051	5118	4295	3573	2940	2387		
	Qac [kW]	--	--	3,91	11,44	18,46	25,0		
	tcu [°C]	49,7	49,7	49,7	49,7	49,7	49,7		
	pm [bar(a)]	--	--	--	--	--	--		
	Qsc [kW]	--	--	--	--	--	--		

-- No calculation possible (see message in single point selection)

*According to EN12900 (10K suction gas superheat, 0K liquid subcooling)

Application Limits Standard HSK7451-70

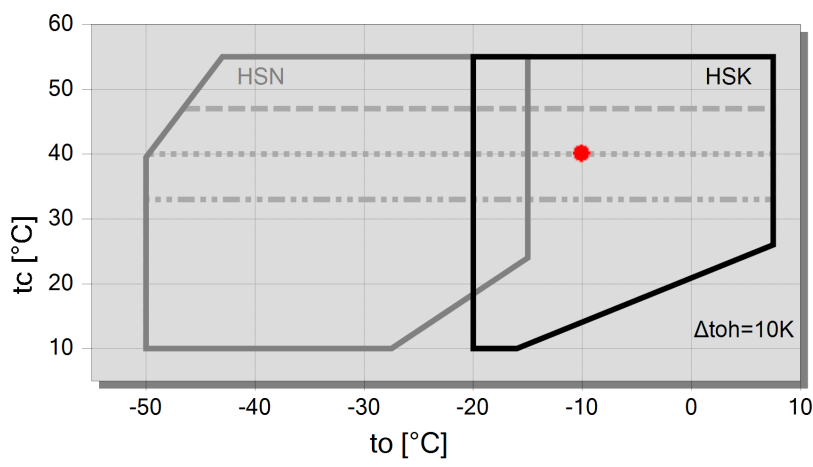

Legend

- max. t_c for frequencies = 20Hz
- max. t_c for frequencies = 25Hz
- max. t_c for frequencies = 35Hz
- A



Technical Data: HSK7451-70

Dimensions and Connections

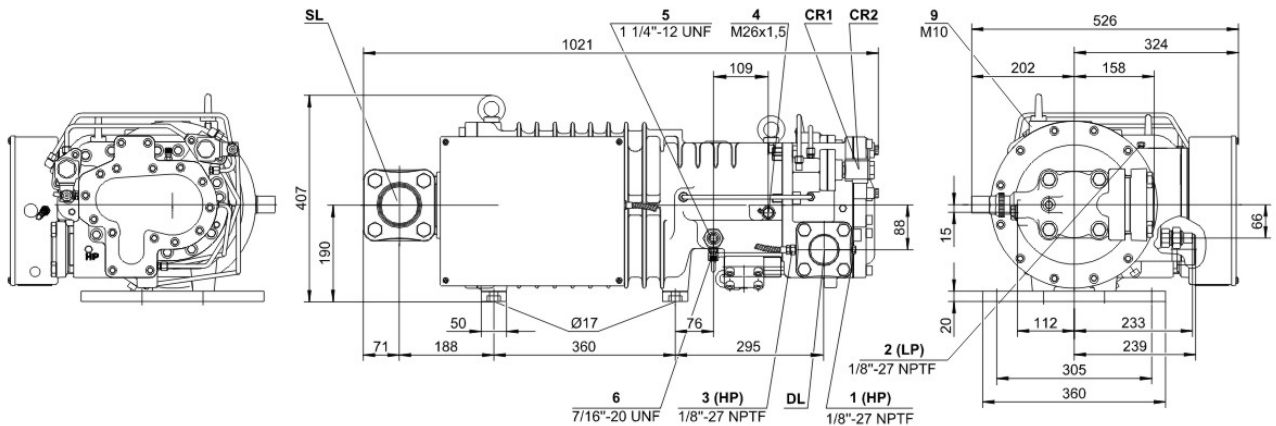

Technical Data

Technical Data

Displacement (2900 RPM 50 Hz)	192 m³/h
Displacement (3500 RPM 60 Hz)	232 m³/h
Weight	305 kg
Max. pressure (LP/HP)	19 / 28 bar
Connection suction line	76 mm - 3 1/8"
Connection discharge line	54 mm - 2 1/8"
Adapter/shut-off valve for ECO	22 mm - 7/8" (Option)
Adapter for liquid injection	16 mm - 5/8" (Option)
Oil type R22	B150SH, B100 (Option)
Oil type R134a/R404A/R507A/R407A/R407F	BSE170 (Option)
Oil type R448A/R449A	BSE170 (Option)

Motor data

Motor voltage (more on request)	380-415V PW-3-50Hz
Max operating current	124.0 A
Starting current (Rotor locked)	290.0 A D / 485.0 A DD
Max. Power input	75,0 kW

Extent of delivery (Standard)

Discharge gas temperature sensor	Standard
Start unloading	Standard
Oil flow control	SE-B2 (Standard)
Motor protection	SE-E1 (Standard), SE-E3 (Standard for 660-690V)
Suction shut-off valve	Standard
Capacity control	100-75-50% (Standard)
Enclosure class	IP54

Available Options

Discharge shut-off valve	Option
ECO connection with shut-off valve	Option
Motor protection	SE-i1 (200-690V)

Sound measurement

Sound power level (-10°C / 45°C)	86,0 dB(A)
Sound pressure level @ 1m (-10°C / 45°C)	78,0 dB(A)



Semi-hermetic Screw Compressors HS

HSK = Application for air-conditioning and medium temperature cooling.

HSN = Application for low temperature cooling.

Notes regarding application limits (see "Limits")

- * Ranges are valid for standard operation and at full-load conditions.
- * With high pressure conditions, part-load operation is partly limited (see application limits in applications manual SH-100).
- * With Economizer operation the maximum admissible evaporation temperature is shifted by 10 K downward (otherwise there is a danger of excessive compression and overload of the motor because of a higher mass flow). At pull-down conditions from higher evaporation temperatures, the ECO injection must remain closed until the evaporation temperature is below the maximum admissible value and a stable operation is achieved (e.g. control of the ECO solenoid valve by means of a low pressure cut-out). The use of the ECO-system with higher evaporation temperatures requires individual consultation with Bitzer.

HS 64/74

- * Capacity control with ECO operation at the same time is limited to one single regulating step (CR 75 %). At CR 50 % the ECO injection should be closed.

Data for sound emission

Data are based on 50 Hz application (IP-units 60 Hz) and R404A.

Sound pressure level: values are based on open air test sites with semi-spherical sound emissions at 1 meter distance. For further information see Technical Information "Sound Data".

Legend of connection positions according to "Dimensions":

- 1 High pressure connection (HP)
 - 1a Additional high pressure connection
 - 1b Connection for high pressure transmitter (HP)
 - 2 Low pressure connection (LP)
 - 2a Additional low pressure transmitter (LP)
 - 2b Connection for low pressure transmitter (LP)
 - 3 Discharge gas temperature sensor connection (HP)
 - 4 Connection for economizer (ECO)
 - HS.85: ECO valve with connection pipe (option)
 - HS.95, OS.85, OS.95: ECO valve (option)
 - 5 Oil injection connection
 - 6 Oil pressure connection for HS.85 and OS.85:
 - Oil drain (compressor housing)
 - 7 Oil drain (motor housing)
 - 7a Oil drain (suction gas filter)
 - 7b Oil drain out of shaft seal (maintenance connection)
 - 7c Oil drain tube (shaft seal)
 - 8 Threaded bore for foot fastening
 - 9 Threaded bore for pipe support (ECO and LI line)
 - 10 Maintenance connection (oil filter)
 - 11 Oil drain (oil filter)
 - 12 Monitoring of oil stop valve
 - 13 Oil filter monitoring
 - 14 Oil flow switch
 - 15 Earth screw for housing
 - 16 Pressure relief (oil filter chamber)
 - 17 Maintenance connection for shaft seal
 - 18 Liquid injection (LI)
 - 19 Compressor module
 - 20 Slider position indicator
 - 21 Oil level switch
 - 22 Connection for oil pressure transmitter
 - 23 Connection for oil and gas return (for systems with flooded evaporator adapter optional)
 - 24 Access to oil circulation restrictor
 - SL Suction gas line
 - DL Discharge gas line
- Dimensions can show tolerances according to EN ISO 13920-B.